



PETROLVALVES GROUP
enabling your energy flow

PRESSURE SEAL GATE VALVES

introduction

PETROLVALVES is a leading manufacturer of valves for the oil and gas industry.

Formed in 1956, **PETROLVALVES** has grown to a company with sales, services and manufacturing facilities throughout the world with direct presence in the United States, Norway, United Kingdom, Italy, Singapore and Australia.

The continuous investment in development of new technology has resulted in the growth and ongoing success of our company. **PETROLVALVES** line of production includes some of the most sophisticated valve products in the world with a strong focus on the development of custom or niche products designed according to customer's specific requirements.

PETROLVALVES has been manufacturing Gate valves since the early 1960s, and has been involved in some of the largest oil & gas projects in the industry.



gate valves
BASIC INFORMATION

STANDARD SERVICE: use in oil and gas production and processing, chemical processing and power generation.

For example:

- ▶ high temperature steam service
- ▶ high temperature process fluid
- ▶ high pressure service
- ▶ pumping, compression and reinjection units
- ▶ offshore platforms
- ▶ onshore terminals

SUB-PRODUCT TYPE

	DESIGN	MODEL
GATE VALVES	Wedge Gate	110
	Parallel Slide Gate	156
	Double Disc Single Expanding	951

01

SPECIAL SERVICE

- ▶ HIGH/LOW TEMPERATURE
- ▶ CRYOGENIC
- ▶ DIRTY / ABRASIVE SERVICE
- ▶ BURIED

RANGE OF PRODUCTION (*)				
ANSI class	150 to 600	900	1500	2500
SIZE	2" to 64"	2" to 54"	2" to 48"	2" to 30"
API 6A class	API 3000	API 5000**	API 10000	API 15000
SIZE	up to 34"	up to 34"	up to 16"	10"
(*) for non listed dimensions contact PV's staff				

gate valves FEATURE

MAIN DESIGN FEATURES	SPECIAL FEATURES	ACCESSORIES
<ul style="list-style-type: none"> ▶ API 600 or API 6A ▶ ASME B16.34 ▶ Metal seated ▶ Fire Safe ▶ Full bore ▶ Bidirectional/Unidirectional ▶ Anti blow out stem ▶ Design for high temperature service 	<ul style="list-style-type: none"> ▶ NACE Requirement ▶ Special bore ▶ Full/partial cladding ▶ Cavity relief ▶ Extended stem ▶ Extended bonnet ▶ Custom engineering to suit customer projects requirements 	<p>Vent & Drain:</p> <ul style="list-style-type: none"> ▶ Plugged ▶ Flanged ▶ With valve <p>Equalizing pipe:</p> <ul style="list-style-type: none"> ▶ With valve <p>Bypass</p> <p>Live loaded packing</p>

PETROLVALVES' engineering department specializes in fulfilling all customer's requirements and project specifications.

gate valves SEALING

PRESSURE SEAL BODY SEALING

The sealing is achieved by the internal pressure that pushes the bonnet against the gasket providing the sealing.

As sealing capability doesn't rely on body/bonnet bolting, this configuration is fit for high temperature service.

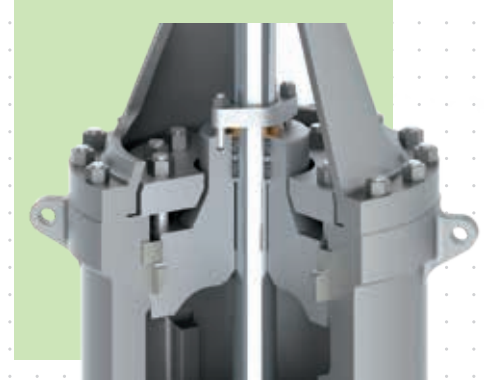

STEM SEALING

Graphite packing for high temperature service.

Availability of API 622 qualified packing and API 624 qualified valves design to fully fulfill API 600 requirements.



03

SEAT SEALING

API 600 design with integral body seat or seal welded separate seat rings.

Renewable threaded seat ring are also available upon request.

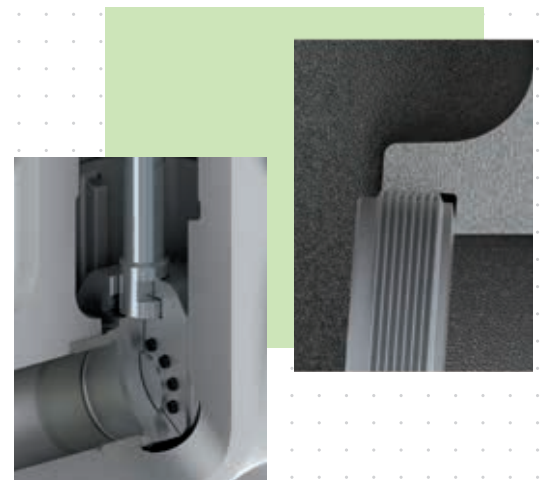

obturator DESIGN

FLEXIBLE WEDGE

Standard flexible wedge design improves the seat tightness and can recover small elastic deformation and thermal expansion, assuring always the optimal contact against the seats.

Solid wedge design or split wedge design is available upon request.



PARALLEL SLIDE

Parallel slide design has obturator made of 2 spring loaded separate plates.

The two plates are free to adjust to temperature fluctuations and to recover high thermal expansions assuring always the best contact against the seat.

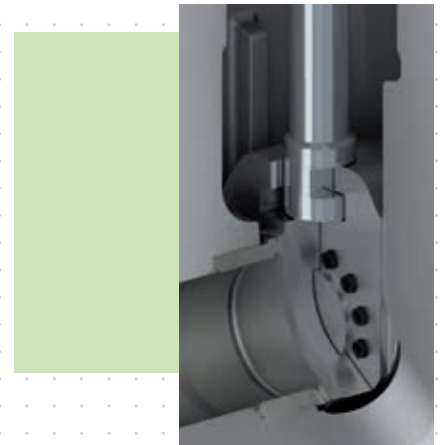

DOUBLE DISC SINGLE EXPANDING

Double disc single expanding design is made of two separate discs with a wedging device that pushes the two discs against the seats achieving excellent sealing capabilities.

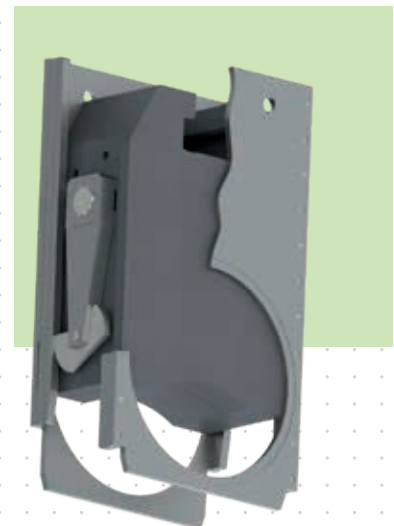

All wedge types are designed to fully comply with API 600 requirements (E.G. wear travel)

materials

PETROLVALVES gate valves have been designed for use with various combinations of materials which are selected to better suit service conditions.

AVAILABLE BODY MATERIAL SELECTION	AVAILABLE OBTURATOR MATERIAL SELECTION	AVAILABLE SEAT MATERIAL SELECTION
<ul style="list-style-type: none"> ▶ CS, LTCS (*) ▶ Low Alloy Steel (*) ▶ Stainless Steel ▶ Ni Alloy <p>(*) CRA weld overlay option available</p>	<ul style="list-style-type: none"> ▶ CS, LTCS ▶ Low Alloy Steel ▶ Austenitic / Ferritic / Martensitic Stainless Steel ▶ Duplex, Superduplex, Ni Alloy <p>Hardfacing</p> <ul style="list-style-type: none"> ▶ stellite 6 or 21 	<ul style="list-style-type: none"> ▶ CS, LTCS ▶ Low Alloy Steel ▶ Austenitic / Ferritic / Martensitic Stainless Steel ▶ Duplex, Superduplex, Ni Alloy <p>Soft seat insert material (optional)</p> <ul style="list-style-type: none"> ▶ PTFE, RPTFE, PCTFE, PEEK, DEVLON, NYLON <p>Hardfacing</p> <ul style="list-style-type: none"> ▶ stellite 6 or 21

For gate valves, material selection can be made following API 600 trim numbers.

05

accessories

CAVITY RELIEF

Piped tubing with a piston check valve connects the body cavity with the high pressure side in order to relieve any overpressure in the cavity. Valves with cavity relief system are unidirectional.

Upon request, we offer a patented cavity relief device that connects the cavity with both sides of the valve, and releases the pressure to the higher pressure side. Valves are bidirectional.

BYPASS

Piping with an on-off valve connects the two sides of the main valve, in case of need the bypass valve can be opened in order to equalize the pressure between upstream and downstream and facilitate the valve opening.

LIVE LOADED PACKING

Packing for low emission service, the packing is loaded by means of belleville washers in order to have a constant load regardless of packing wear.



PETROLVALVES GROUP
enabling your energy flow